

## EXACT GUIDANCE – IT'S ALL A MATTER OF ADJUSTMENT

**Spieth guide bushings – round guiding and clamping elements with adjustable play.**

Spieth guide bushings open up new dimensions for contemporary, efficient and economical machine designs incorporating high power densities and high levels of dynamic stress. That's because the simple to produce surrounding components can be manufactured to standard ISO tolerance levels. The required fine guidance play can be optimally adjusted during the mounting process. Minor geometrical errors in the surrounding components as well as operational influences such as increasing temperature can be taken into account – and play can easily be re-adjusted later on.

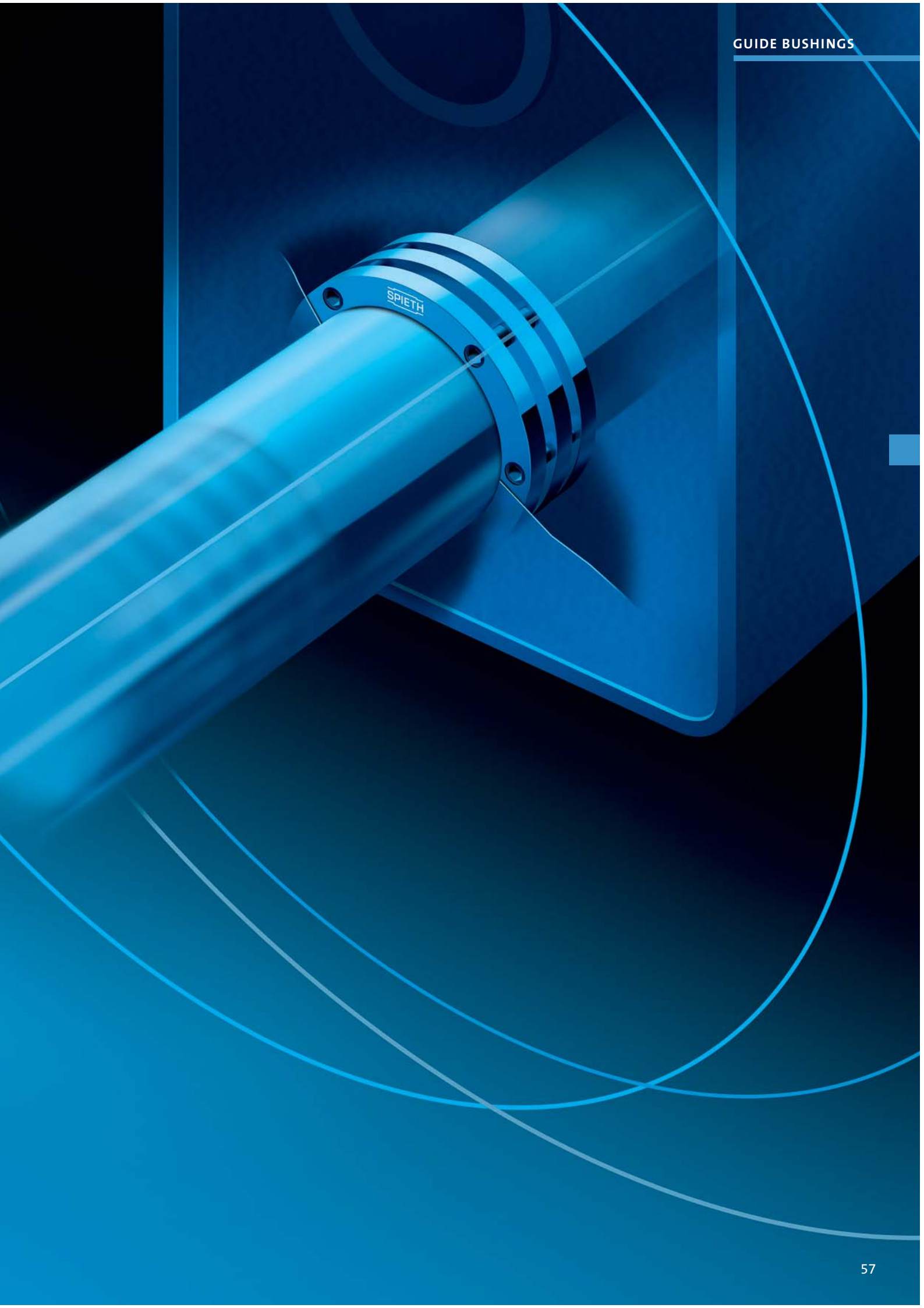

# SPIETH GUIDE BUSHINGS

## BENEFITS

---

- Low-cost, ready-to-mount guide and clamping bushing.
- Existing mating play ensures simple mounting even with large dimensions.
- Optimum guide play adjustment for any operating status.
- Metallic support between clamped sleeve and housing affords high radial rigidity.
- Provides typical high damping performance characteristics for slideways.
- Precise central play restriction and clamping of the sleeve or column.



## FIELDS OF APPLICATION

Spieth guide bushings are round linear guiding elements for use in construction and mechanical engineering. The use of guiding bushes is called for wherever the benefits of slideways, such as high levels of damping combined with minimal guide play are required. As a result, guide bushings are successfully used on guide frames, cylindrical carriage guides, on tailstock sleeves, press rams etc. In addition to linear movement, simultaneous rotary movements are possible. However, due to the constraints imposed by lubrication technology, pure rotation such as that used for sliding bearings is not permitted. High ac-

celeration values are possible, as long as an adequate supply of lubrication is ensured.

Series FAK/FAL guiding bushes are round linear guiding and clamping elements for precise sleeve or column guidance in applications where the sleeve/column also has to be clamped precisely and centrally in any position. This is required, for example, for sleeves on machine tools in which absolute freedom from play at standstill is called after positioning. The sequence of clamping and release can be repeated as often as required.



## FUNCTIONAL PRINCIPLE

### FDK/FDL, FSK/FSL

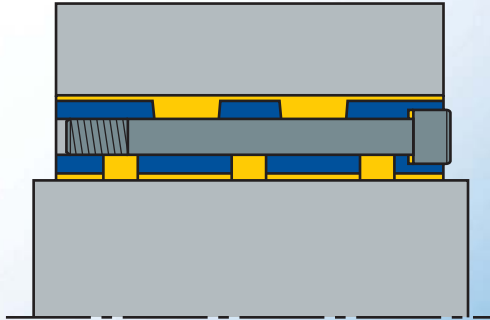

Connection with assembly play between the housing, guide bushing and centre sleeve.

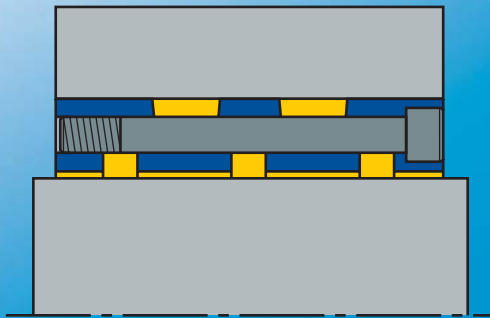

First phase of axial pre-stress: Mating play between housing and guide bushing eliminated, firm fit realized.

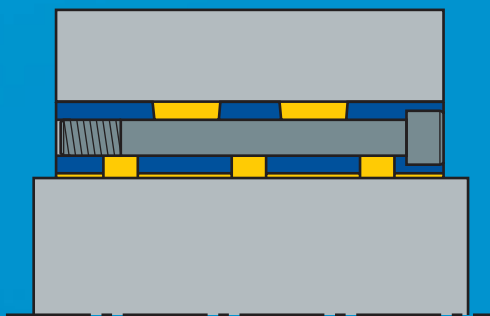

After further axial pre-stressing, the guide play between the guide bushing and sleeve is optimally adjusted.

### FAK/FAL

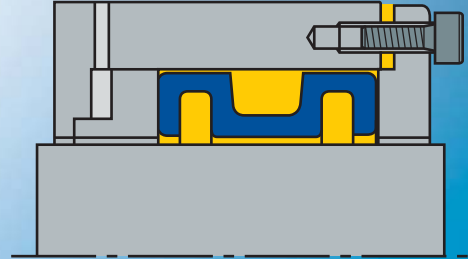

Mounting situation: Connection with assembly play between the housing, guide bushing and centre sleeve.

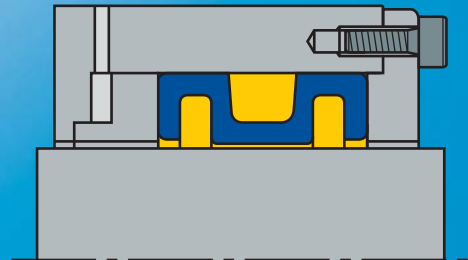

Guide play adjusted: The guide bushing fits firmly in the housing; guide play between guide bushing and sleeve is optimally adjusted.

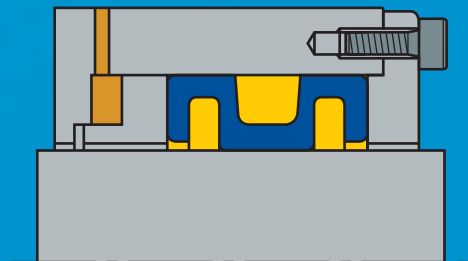

Sleeve clamped: Absolute freedom from play between the sleeve and housing due to tensioned guide bushing.

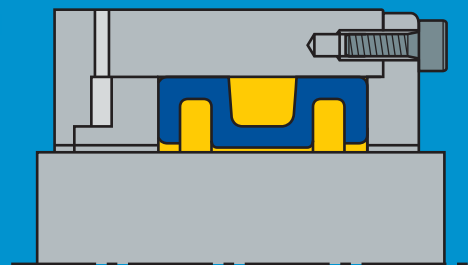

Sleeve released for free movement: The guide bushing has released the sleeve with the previously set degree of guide play.

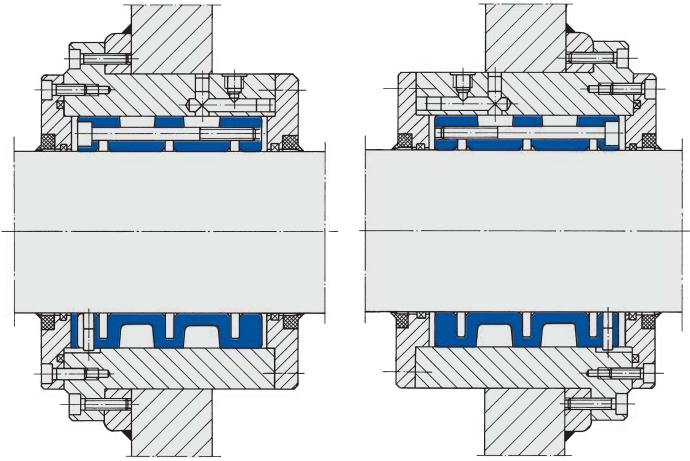
**Example 1: Round guide**

Due to the long guidance basis of the guide bushings on a welded machine column, particular attention must be paid to ensuring a precisely flush housing borehole.

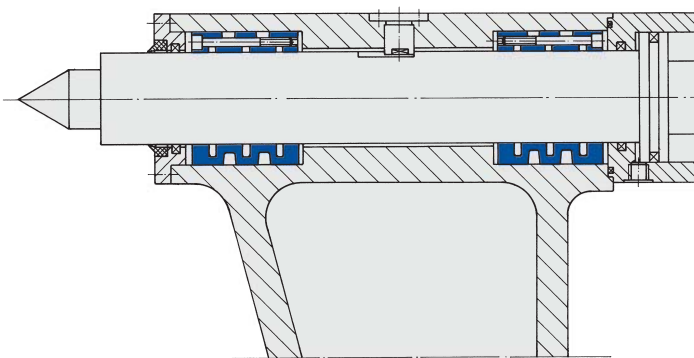
**Example 2: Sleeve guide**

In a tailstock, minimal guide play can be achieved here during the installation process. Guide play readjustment is possible at any time. Grease lubrication with facility for occasional re-lubrication is sufficient here.

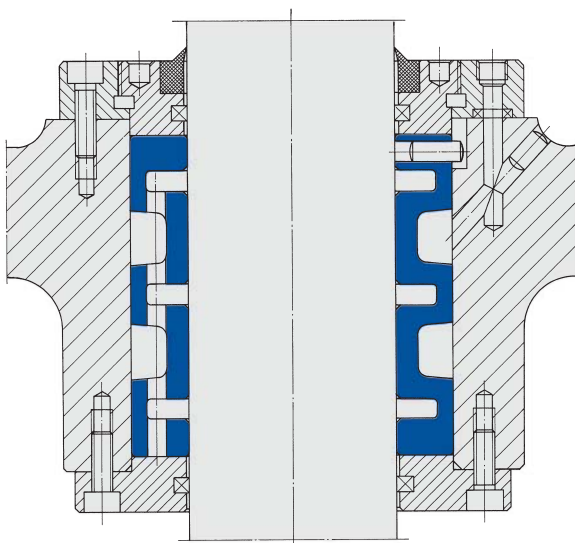
**Example 3: Column guide**

Guide play adjustment using threaded ring. A locating fit at the threaded ring ensures the necessary rectangular face contact at the guide bushing. The required feed path can be specified when the flange cover has not yet been tightened by turning the threaded ring. The guide bushing is then pre-stressed by tightening the screws at the flange cover.

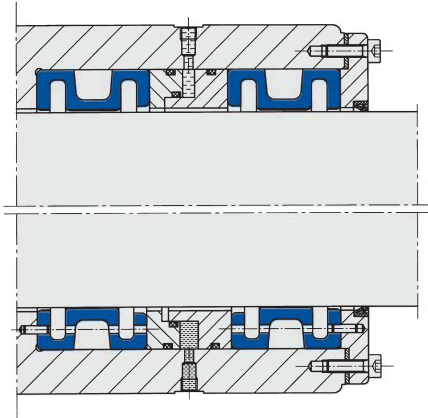

**Example 4: Sleeve guidance and clamping**

In this example, the working sleeve of a machine tool is precisely guided by two FAK series guide bushings. In the stationary working position of the sleeve or column, clamping using the spring-hardened guide bushing guarantees absolute freedom from play as well as a high degree of radial rigidity in the guide system.

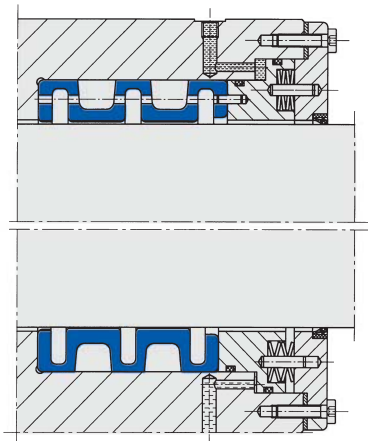

**Example 5: Safety clamping**

Safety requirements (power failures, oil pressure drop) or economic considerations (long clamping and short release times) often call for a mechanically acting clamp. In this case, the FAL series guide bushing is clamped using banks of cup springs (lower half of the picture) and hydraulically released (upper half of the picture).

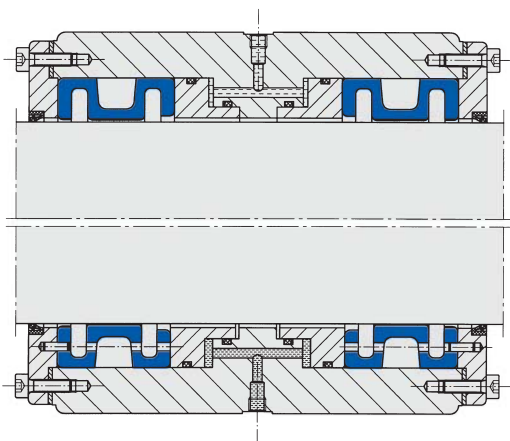

**Example 6: Guide play compensation**

In the arrangement shown here, an independent guide play setting is possible for each guide bushing. This allows the ever-present minimal influence of the different actual guide bushing dimensions and housing boreholes to be compensated. Where expedient for certain requirements, differing degrees of guide play can be set at the two guide bushings.

# SPIETH GUIDE BUSHINGS: THE RIGHT CHOICE

We'll provide you with the perfect guide bushings for your application. We'll also help you choose the right one – with expert advice from our specialists.

### Series FDK/FDL and FSK/FSL

- Precision round guiding elements with adjustable play.
- Low-cost, ready-to-mount.
- Sliding friction in combination with minimum guide play possible.
- Adjustable during installation.
- Connecting components simple to manufacture.
- High degree of damping.
- Simple, quick assembly and dismantling.

### Series FAK/FAL

- Round guiding and clamping elements with precisely adjustable play.
- Low-cost, ready-to-mount.
- High degree of radial rigidity.
- High degree of damping.
- Simple, quick assembly and dismantling, even with large dimensions.

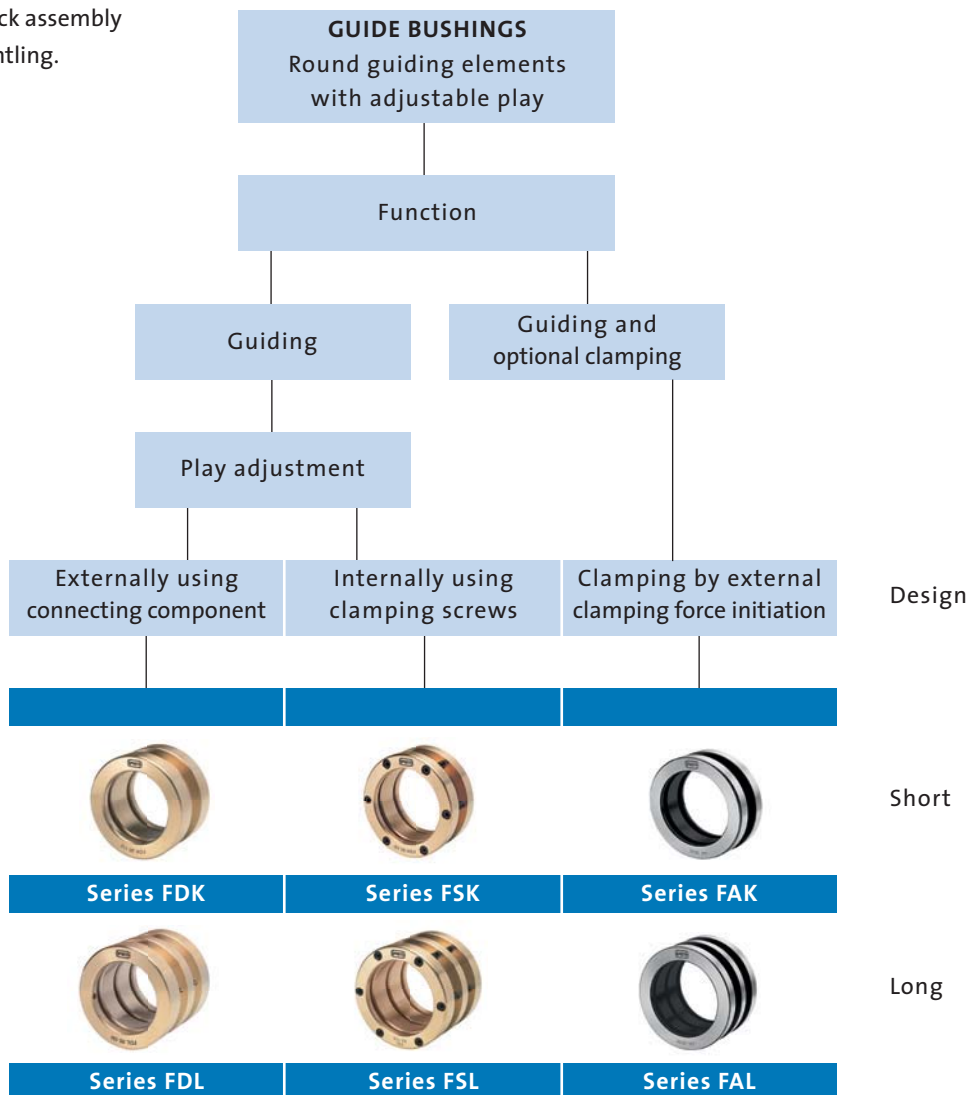



# SPIETH GUIDE BUSHINGS SERIES FDK/FDL

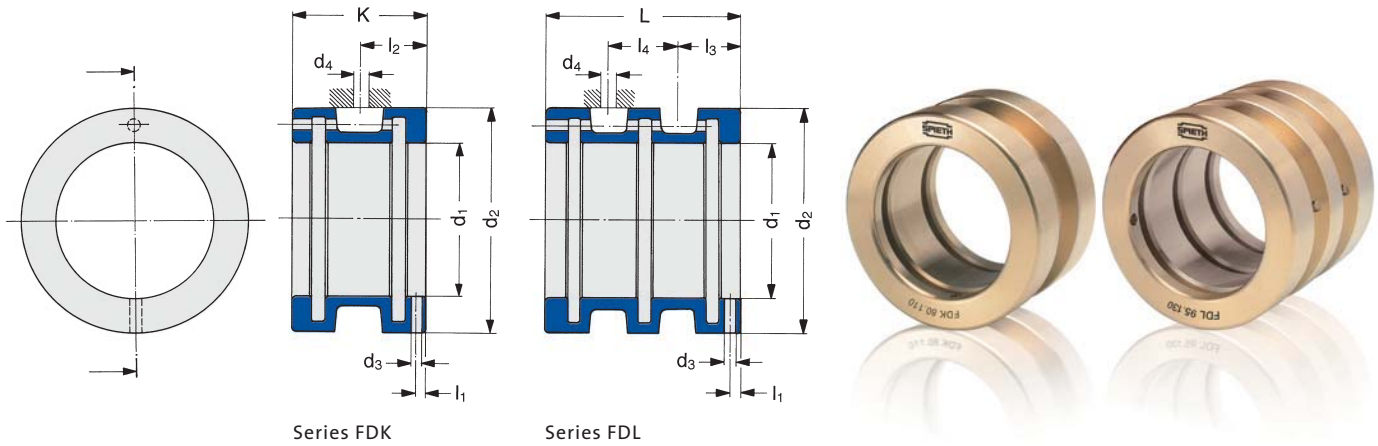

Order No.	Dimensions in mm										Perm. radial stress (Guideline values)	
	d <sub>1</sub> H6 <sup>1)</sup>	d <sub>2</sub> h5	K	L	d <sub>3</sub> H7	l <sub>1</sub>	l <sub>2</sub>	l <sub>3</sub>	l <sub>4</sub>	d <sub>4</sub> max.	FDK	FDL
20.37	20	37	30	46	3	2.5	15	15	16	6	1800	3600
25.42	25	42	30	46	3	2.5	15	15	16	6	2260	4500
30.47	30	47	30	46	3	2.5	15	15	16	6	2810	5720
35.55	35	55	42	62	4	3.5	21	20	22	10	5290	9070
40.62	40	62	42	62	4	3.5	21	20	22	10	6050	10370
45.68	45	68	42	62	4	3.5	21	20	22	10	6800	11660
50.72	50	72	42	62	4	3.5	21	20	22	10	7560	12960
55.80	55	80	42	68	4	3.5	21	21.5	25	12	8320	16630
60.85	60	85	42	68	4	3.5	21	21.5	25	12	9070	18140
65.90	65	90	42	68	4	3.5	21	21.5	25	12	9830	19660
70.100	70	100	48	78	4	3.5	24	24	30	14	12100	25200
75.105	75	105	48	78	4	3.5	24	24	30	14	12960	27000
80.110	80	110	48	78	4	3.5	24	24	30	14	13820	28800
85.120	85	120	60	92	5	4.5	30	28.5	35	16	20810	36110
90.125	90	125	60	92	5	4.5	30	28.5	35	16	22030	38230
95.130	95	130	60	92	5	4.5	30	28.5	35	16	23260	40360
100.140	100	140	66	102	5	5.5	33	31.5	39	16	25920	47520
110.150	110	150	66	102	5	5.5	33	31.5	39	16	28510	52270
120.165	120	165	72	114	6	6	36	36	42	16	34560	58750
130.180	130	180	78	124	6	6	39	39	46	16	41180	71140
140.190	140	190	78	124	6	6	39	39	46	16	44350	80640
150.200	150	200	78	124	6	6	39	39	46	16	47520	86400

<sup>1)</sup> As the guide borehole is machined while the guide bushing is in a preloaded condition, control measurement of the guide bushing is not possible in its delivered, non-loaded state.

Designation of a guide bushing with  $d_1 = 40$  mm,  $d_2 = 62$  mm and  $K = 42$  mm: Guide bushing **FDK 40.62**.

## SPIETH GUIDE BUSHINGS SERIES FSK/FSL

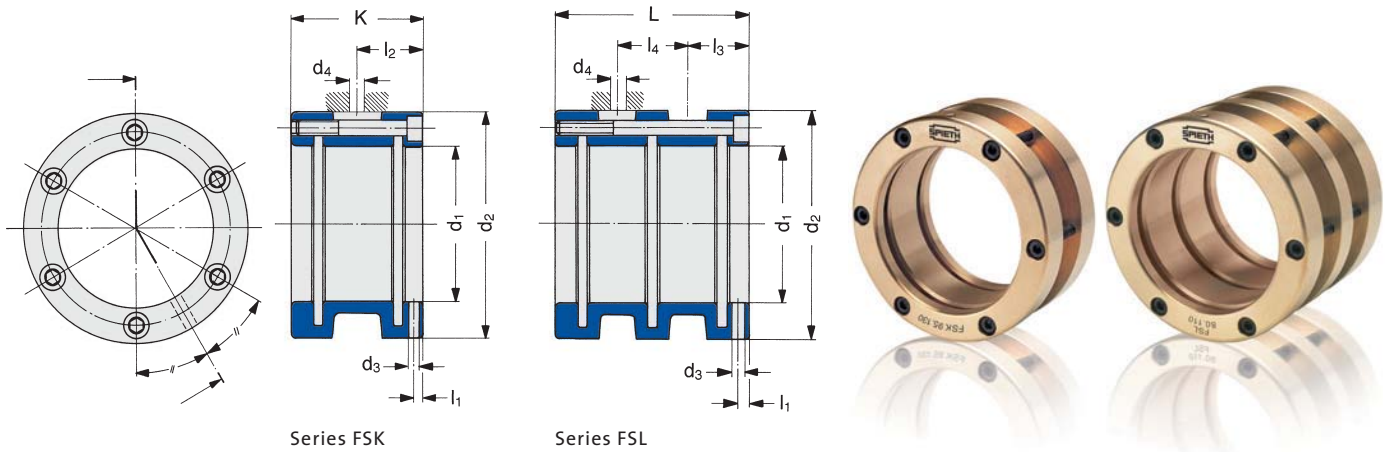

Order No.	Dimensions in mm										Clamping screws		Perm. radial stress (Guideline values)	
	d <sub>1</sub> H6 <sup>1)</sup>	d <sub>2</sub> h5	K	L	d <sub>3</sub> H7	l <sub>1</sub>	l <sub>2</sub>	l <sub>3</sub>	l <sub>4</sub>	d <sub>4</sub>	ISO 4762	No.	FSK	FSL
20.37	20	37	30	46	3	2.5	15	15	16	6	M4	4	1800	3600
25.42	25	42	30	46	3	2.5	15	15	16	6	M4	4	2260	4500
30.47	30	47	30	46	3	2.5	15	15	16	6	M4	6	2810	5720
35.55	35	55	42	62	4	3.5	21	20	22	10	M4	6	5290	9070
40.62	40	62	42	62	4	3.5	21	20	22	10	M4	6	6050	10370
45.68	45	68	42	62	4	3.5	21	20	22	10	M5	6	6800	11660
50.72	50	72	42	62	4	3.5	21	20	22	10	M5	6	7560	12960
55.80	55	80	42	68	4	3.5	21	21.5	25	12	M5	6	8320	16630
60.85	60	85	42	68	4	3.5	21	21.5	25	12	M5	6	9070	18140
65.90	65	90	42	68	4	3.5	21	21.5	25	12	M5	6	9830	19660
70.100	70	100	48	78	4	3.5	24	24	30	14	M5	6	12100	25200
75.105	75	105	48	78	4	3.5	24	24	30	14	M5	6	12960	27000
80.110	80	110	48	78	4	3.5	24	24	30	14	M5	6	13820	28800
85.120	85	120	60	92	5	4.5	30	28.5	35	16	M6	6	20810	36110
90.125	90	125	60	92	5	4.5	30	28.5	35	16	M6	6	22030	38230
95.130	95	130	60	92	5	4.5	30	28.5	35	16	M6	6	23260	40360
100.140	100	140	66	102	5	5.5	33	31.5	39	16	M6	6	25920	47520
110.150	110	150	66	102	5	5.5	33	31.5	39	16	M6	6	28510	52270
120.165	120	165	72	114	6	6	36	36	42	16	M6	8	34560	58750
130.180	130	180	78	124	6	6	39	39	46	16	M8	8	41180	71140
140.190	140	190	78	124	6	6	39	39	46	16	M8	8	44350	80640
150.200	150	200	78	124	6	6	39	39	46	16	M8	8	47520	86400

<sup>1)</sup> As the guide borehole is machined while the guide bushing is in a preloaded condition, control measurement of the guide bushing is not possible in its delivered, non-loaded state.

Designation of a guide bushing with integrate clamping screws,  $d_1 = 60$  mm,  $d_2 = 85$  mm and  $K = 42$  mm: Guide bushing **FSK 60.85**.

# SPIETH GUIDE BUSHINGS SERIES FAK

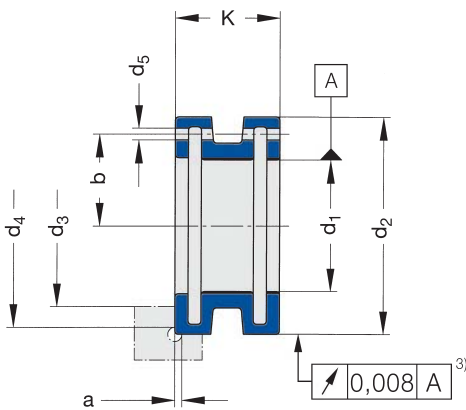

Order No.	Dimensions in mm					Clamping initiation		Transmittable forces		Dim. connect. comp. in mm		
	$d_1$	$d_2$	$K$	Fixing hole		$F_{max}$	$C_{min}^{(2)}$	$M$	$F_a$	$d_3$ max.	$d_4$ min.	$a$ max.
	G6	h5		$d_5$	$b$	N	mm	Nm	N			
FAK 35.52	35	52	21	3.8	22	22900	0.4	100	5710	43	50	2.2
FAK 40.56	40	56	21	3.8	24	25900	0.4	131	6550	48	54	2.2
FAK 45.68	45	68	26	3.8	28	29800	0.4	180	8000	58	65	3
FAK 50.72	50	72	26	3.8	30	32900	0.4	221	8840	62	69	3
FAK 55.80	55	80	31	3.8	33	39300	0.5	295	10730	70	77	3
FAK 60.85	60	85	31	4.8	36	42200	0.5	352	11730	75	82	3
FAK 65.90	65	90	31	4.8	38	45100	0.5	421	12950	80	87	3
FAK 70.100	70	100	38	4.8	42	52500	0.5	546	15600	88	96	4
FAK 75.105	75	105	38	4.8	44	55600	0.5	619	16510	93	101	4
FAK 80.110	80	110	38	4.8	46	58700	0.5	709	17730	98	106	4
FAK 85.115	85	115	38	4.8	50	61800	0.6	793	18660	103	111	4
FAK 90.120	90	120	38	4.8	53	64800	0.6	909	20200	108	116	4
FAK 100.130	100	130	38	5.8	58	71000	0.6	1123	22460	118	126	4
FAK 110.140	110	140	38	5.8	63	77100	0.6	1342	24400	128	136	4
FAK 120.150	120	150	38	5.8	68	83300	0.6	1606	26770	138	146	4
FAK 130.160	130	160	38	5.8	73	89500	0.6	1869	30290	148	156	4
FAK 140.170	140	170	38	5.8	78	95700	0.6	2185	31210	158	166	4
FAK 150.180	150	180	38	5.8	83	101900	0.6	2491	33210	168	176	4

<sup>2)</sup> Design specification, not to be confused with actuation travel. For explanations, see p. 71.

<sup>3)</sup>  $d_2 > 80$  mm = Concentricity to IT4

## SPIETH GUIDE BUSHINGS SERIES FAL

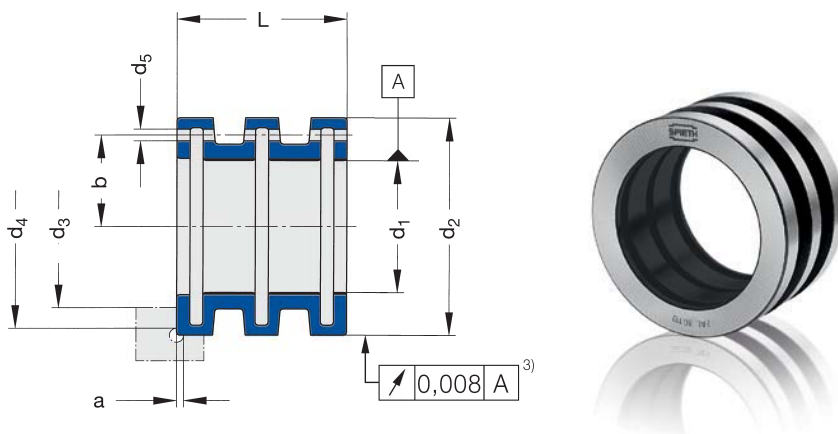

Order No.	Dimensions in mm					Clamping initiation		Transmittable forces		Dim. connect. comp. in mm		
	d <sub>1</sub>	d <sub>2</sub>	L	Fixing hole		F <sub>max</sub>	C <sub>min</sub> <sup>2)</sup>	M	Fa	d <sub>3</sub>	d <sub>4</sub>	a
	G6	h5		d <sub>5</sub>	b	N	mm	Nm	N	max.	min.	max.
FAL 35.52	35	52	35	3.8	22	22900	0.6	149	8510	43	50	2.2
FAL 40.56	40	56	35	3.8	24	25900	0.6	195	9750	48	54	2.2
FAL 45.68	45	68	42	3.8	28	29800	0.6	261	11600	58	65	3
FAL 50.72	50	72	42	3.8	30	32900	0.6	321	12840	62	69	3
FAL 55.80	55	80	52	3.8	33	39300	0.8	427	15530	70	77	3
FAL 60.85	60	85	52	4.8	36	42200	0.8	506	16870	75	82	3
FAL 65.90	65	90	52	4.8	38	45100	0.8	600	18460	80	87	3
FAL 70.100	70	100	62	4.8	42	52500	0.8	770	22000	88	96	4
FAL 75.105	75	105	62	4.8	44	55600	0.8	874	23310	93	101	4
FAL 80.110	80	110	62	4.8	46	58700	0.8	995	24880	98	106	4
FAL 85.115	85	115	62	4.8	50	61800	0.9	1113	26190	103	111	4
FAL 90.120	90	120	62	4.8	53	64800	0.9	1234	27420	108	116	4
FAL 100.130	100	130	62	5.8	58	71000	0.9	1521	30420	118	126	4
FAL 110.140	110	140	62	5.8	63	77100	0.9	1817	33040	128	136	4
FAL 120.150	120	150	62	5.8	68	83300	0.9	2165	36080	138	146	4
FAL 130.160	130	160	62	5.8	73	89500	0.9	2520	38770	148	156	4
FAL 140.170	140	170	62	5.8	78	95700	0.9	2935	41930	158	166	4
FAL 150.180	150	180	62	5.8	83	101900	0.9	3349	44650	168	176	4

<sup>2)</sup> Design specification, not to be confused with actuation travel. For explanations, see p. 71.

<sup>3)</sup> d<sub>2</sub> > 80 mm = Concentricity to IT4

**Application**

Before mounting, all parts belonging to the round guide must be carefully cleaned and wet slightly using low viscosity machine oil.

**Assembly of series FDK – FDL:**

1. Insert the guide bushing in the housing borehole. If an orientation pin is fitted, this must not come to rest axially against the groove in the housing.
2. Mount the flange cover loosely without the shim ring and insert the sleeve.
3. Tighten the clamping screws in the flange cover evenly crosswise until loss of play in the centre sleeve is indicated by stiffer sliding action of the sleeve. Check the parallelism of the mounting gap for the shim ring and correct if necessary.
4. Gauge the mounting gap for the shim ring, remove the flange cover.
5. Adjust the height of the shim ring. Recommendation: measured mounting gap + approx. 0.02 mm for contact surface compression.
6. Mount the flange cover and the underneath shim ring, tighten the screws crosswise.
7. Check the guide play. If necessary, correct by reworking the shim ring (reducing guide play) or the flange cover (increasing guide play). Guideline value: 0.1 mm alteration of the height corresponds to ~ 0.01 mm alteration in diameter.

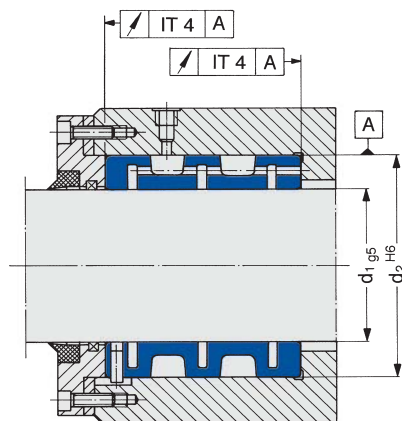

Fig. 1

**Assembly of series FSK – FSL:**

1. Insert the guide bushing in the housing borehole. If an orientation pin is fitted, this must not come to rest axially against the groove in the housing.
2. Tighten the clamping screws in the flange cover evenly crosswise until the guide bushing is seated firmly in the housing. Even actuation of the clamping screws can be achieved by tightening in each case by a certain angular amount (e.g. 30°). Specifying a certain degree of torque for the clamping screws is a less suitable method of ensuring uniform guide play adjustment.
3. Insert the sleeve and continue tightening the clamping screws – as described above – until the desired loss of play is indicated by stiffer sliding action of the sleeve.
4. Remove the sleeve, apply a thin coating of inking paste and re-insert in the guide bushing to check the contact pattern.
5. Move the sleeve backwards and forwards with an oscillating motion, remove and inspect the ink impression left on the guide bushing.
6. Should the surface impression be incomplete, insert the sleeve again and tighten the screws in the sector, which is not making correct contact. Stop tightening when you notice the sleeve running more stiffly in the bushing.
7. After optimising the contact pattern, clean the sleeve and guide bushing borehole, oil and re-insert the sleeve.

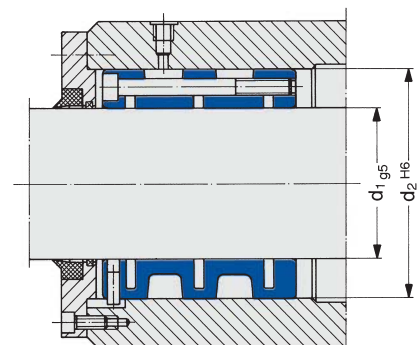

Fig. 2

**Assembly of series FAK – FAL:**

The guide bushing may only be clamped if its borehole and outer surfaces are covered by the connecting components. Otherwise the guide bushing could be destroyed as a result of plastic deformation.

1. Insert the guide bushing and ring piston into the housing borehole without exerting force.
2. Mount the flange cover loosely without the shim ring and insert the sleeve.
3. Tighten the clamping screws in the flange cover evenly crosswise until loss of play in the centre sleeve is indicated by stiffer sliding action of the sleeve. Check the parallelism of the mounting gap for the shim ring and correct if necessary.
4. Gauge the mounting gap for the shim ring, remove the flange cover.
5. Adjust the height of the shim ring. Recommendation: Measure mounting gap + approx. 0.02 mm for contact surface compression.
6. Mount the flange cover and the underneath shim ring, tighten the screws crosswise.

7. Check the guide play. If necessary, correct by reworking the shim ring (reducing guide play) or the flange cover (increasing guide play).

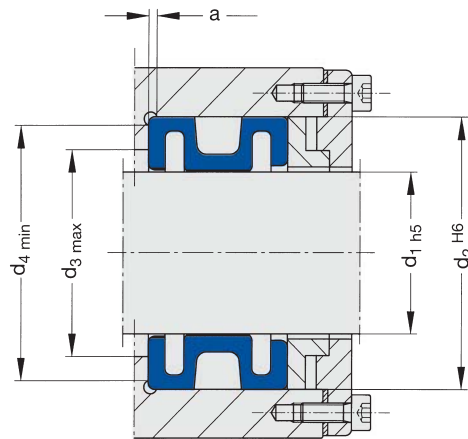

Fig. 3: Mounting assembly showing design of connecting components

**Clamping**

To obtain complete freedom from play between the sleeve and housing, the guide bushing is hydraulically clamped by the ring piston once it has been adjusted for optimum guide play. For further arrangements with mechanical or hydraulic clamping, see the assembly examples.

The length of the guide bushing is reduced during the clamping process by a few tenths of a mm (depending on the size of the guide bushing, the clamping force and the actual dimensions of the connecting components) and in the process, it drags the part to be clamped in the clamping direction. If the guide bushings are arranged in pairs (e.g. Example 4, p. 62) with opposing clamping direction, this thrust effect is theoretically cancelled. However, due to minimal geometrical differences

and changing coefficients of friction, even in this case a residual thrust in the range of hundredths of a mm can occur in an undetermined direction. As it is caused by the actual circumstances, this phenomenon is reproducible. FAK series guide bushings can be supplied as a special non-standard low-thrust version on request; but the retention force in this version only reaches 0.5 times that of the table values.

## DESIGN

---

### **Series FDK/FDL, FSK/FSL**

The guide bushings are made of high-grade bearing bronze. The guide borehole is precision turned to ISO tolerance H6, the outside diameter to ISO tolerance h5. As the guide borehole is machined while the guide bushing is in a pre-stressed condition, control measurement of the guide bushing is not possible in its delivered, non-stressed state. The radial borehole for fitting the cylindrical pin is machined to ISO tolerance H7. In the FDK/FDL series, lubricant is distributed to the various chambers by means of an additional borehole. In the FSK/FSL series, the space between the clamping screws and the through holes is used for this purpose. The lubricants used are predominantly mineral oils, whose viscosity is adjusted to the respective operating conditions.

For orientation, the guide bushings are equipped with a hole for a fixing pin ( $d_3$ ). The necessary supply of lubrication is implemented by means of another borehole ( $d_4$ ). The design of the housing must be adapted accordingly.

### **Series FAK/FAL**

The guide bushings are manufactured from spring-hardened steel. The borehole has a plastic slide coating. The outside diameter is machined to ISO tolerance h5, the borehole to ISO tolerance G6. The maximum run-out of the borehole – outside diameter – end faces is 0.01 mm.

## CLAMPING SCREWS

---

Clamping screws in series FSK/FSL are cheese-head screws with a hexagon socket ISO 4762

(DIN 912), which are tightened with an ISO 2936 (DIN 911) screwdriver.

## CONNECTING COMPONENTS

---

The connecting components (housing borehole, shaft/sleeve) must be configured in such a way that the entire inside and outside surfaces of the guide bushing are covered at all times.

When series FDK/FDL and FAK/FAL guide bushings are used, all contact end faces of the connecting components, which represent functional surfaces, must be configured precisely at right angles to the axis.

### **Housing borehole**

Manufacturing tolerance H6, concentricity and cylindricity within IT 3, surface roughness  $R_z$  max. 6.3  $\mu\text{m}$ .

### **Sleeve on bronze bushes of series FDK/FDL, FSK/FSL**

Manufacturing tolerance of the sleeve: g5, surface roughness  $R_z = 1\mu\text{m}$ . The quality of the round guide depends to a large degree on the cylindricity and the concentricity of the sleeve. Therefore, the minimum degree of geometrical error must be aimed for in this case. We recommend adhering to tolerance level IT 2 (ISO).

### **Shaft in steel bushings of series FAK/FAL**

Manufacturing tolerance of the shaft: h5, concentricity and cylindricity within IT 3, surface roughness  $R_z$  max. 6.3  $\mu\text{m}$ . We recommend the following experience value for the minimum housing wall thickness:

$$C_{45} = 0.4 (D - d)$$

$$GG_{25} = 0.7 (D - d)$$

**Series FAK/FAL**

In conjunction with the lubrication, the plastic coating of the guide bushings ensures smooth-running, low-wear guidance. However, the good sliding properties of the bushing have a detrimental effect on the transmittable forces. Therefore the table values "transmittable forces" should only be regarded as non-binding guideline values.

**F:** Maximum permissible clamping force.

**C: Required functional installation space**

Spieth clamping sleeves must be clamped using the controlled application of force. The clamping force cannot be applied in relation to the clamping path. To prevent premature blocking, a "free" functional path "C" must be provided.

**M:** Transmittable torque at  $F_a = 0$ .

**F<sub>a</sub>:** Transmittable axial force at  $M = 0$ .

The  $F_a$  values are calculated according to

$$F_a = 2000 \cdot \frac{M}{d_1} \text{ [N]}$$

**M and F<sub>a</sub>:** If both torque and axial forces act on a guide bushing at the same time, check using the following formula whether the resulting torque  $M_r$  is transmittable:

$$M \geq M_r = \sqrt{M_e^2 + \left(\frac{F_{ae} \cdot d_1}{2000}\right)^2} \text{ [Nm]}$$

If it is not possible to apply the clamping force  $F$ , the following formula is used for the approximate determination of the torque  $M_{red}$  which can be transmitted with the given clamping force  $F_{giv}$  ( $<F$ ).

$$M_{red} = \frac{M (F_{giv} - 0.05 F)}{0.95 F} \text{ [Nm]}$$

To ascertain the necessary clamping force for a transmittable torque  $M_{red} < M$ , an approximation is possible using the following formula:

$$F_{req.} = \frac{M_{red} \cdot 0.95 F}{M} + 0.05 F \text{ [N]}$$

**M** = Transmittable torque (catalogue value) [Nm]

**M<sub>e</sub>** = Required torque [Nm]

**M<sub>r</sub>** = Resulting torque [Nm]

**M<sub>red</sub>** = Reduced transmittable torque [Nm]

**F** = Max. perm. clamping force (catalogue value) [N]

**F<sub>ae</sub>** = Required axial force [N]

**F<sub>req.</sub>** = Required clamping force [N]

**F<sub>giv.</sub>** = Given clamping force ( $<F$ ) [N]

**d<sub>1</sub>** = Shaft diameter [mm]